

2013



**WESTERN**™

PRODUCTS OF INDIANA





# Box or Round

You're on the right track with



Whether you use box track or round track, you'll find the strength, shape, and size, you desire in door tracks, hangers, trolleys, brackets, sliding door accessories, door frames and horse stalls from **Western Products**.

Choose from our box track options of **400 lb.** to **1,000 lb.** capacity, or our round track at **600 lb.** capacity. Discover the convenience of **Western's** complete product line.

**Western** is known for its customer service and customer loyalty. Most of our track orders are shipped from inventory within 3 to 5 business days.

**Quality, Service, and Pricing** is important to this family-owned and operated company and has been since **1929**. A lot has changed since then, but not the commitment to service our customers!. Call us with your requirements today, and lets build the future together.

visit us at [WesternProductsInc.com](http://WesternProductsInc.com)

# BOX TRACK OPTIONS

## #2 Track

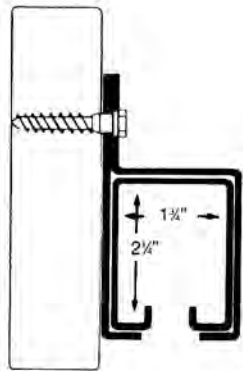

Versatile and popular. Use with any bracket shown on pages 5 and 6. For single track runs, space brackets 24" on center. Double-track runs require brackets every 18" o.c. respectively. Track is 16 gauge galvanized steel. Available in 8, 10, 12, 14, 16, 20, and 24 foot lengths.

## #7 Track

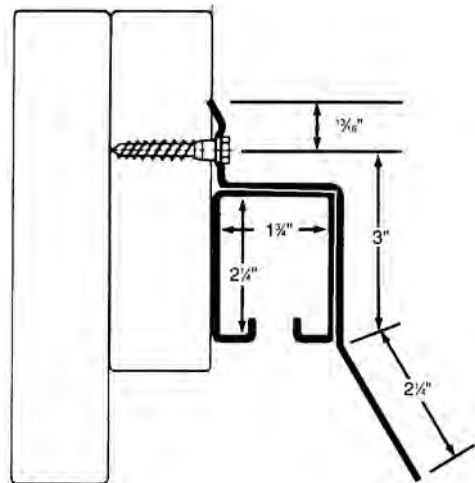

Works well with new construction or remodeling projects. Extra-wide galvanized cover is mechanically attached to box track and shields top of door from rain, snow, and ice. No brackets or flashing required. Mount with 5/16" lag screws or bolts. Available in 8, 10, and 12 foot lengths.

## #8 Track

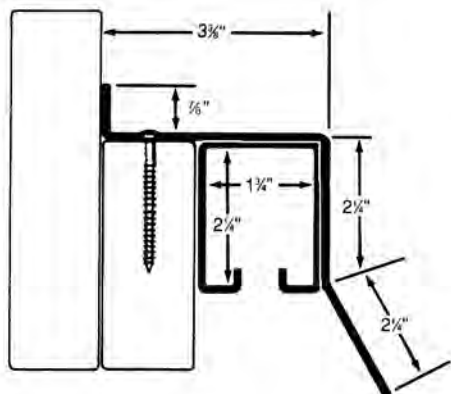

The ultimate labor-saving track. No brackets or flashing required with the prepainted white cover; attach with 1-1/2" ring-shank neoprene washer nails. White cover is mechanically attached to box track and shields top of door from rain, snow, and ice. Available in 8, 10, and 12 lengths.

Box track, 16 gauge galvanized steel for doors weighing up to 400 lbs. To order, specify track number and length, in bundle quantities per price list.

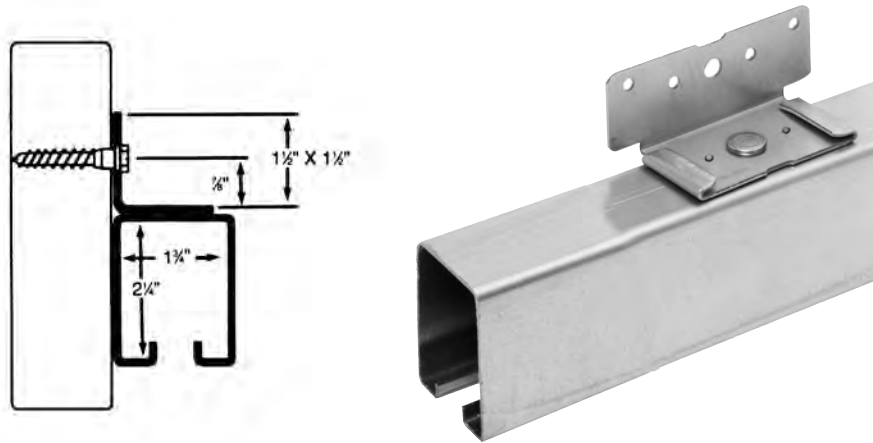

## #9 Track

Face mount track attaches with 5/16" lag screws or bolts. Mounting brackets are approximately 24" on center and attached with rivets at the factory. Available in 8, 10, 12, 14, 16, and 20 foot lengths.

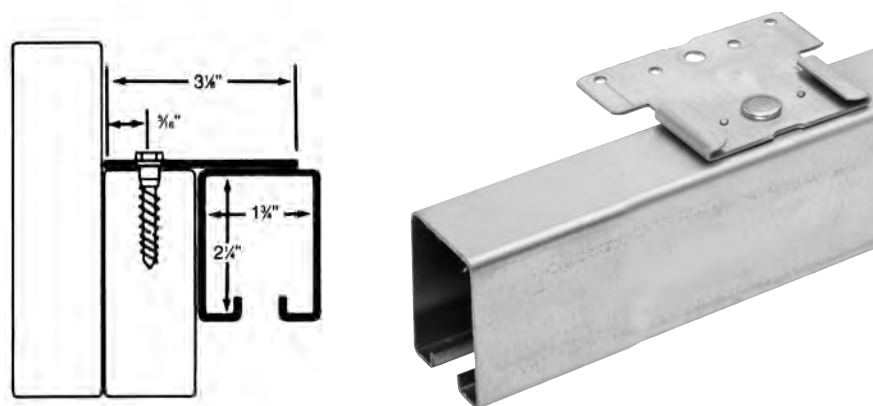

## #10 Track

Top mount track attaches with 1-1/2" ring shank neoprene washer nails. (5/16" lag screws or bolts may also be used if desired.) Mounting brackets are approximately 24" on center and attached with rivets at the factory. Available in 8, 10, 12, 14, 16, and 20 foot lengths.

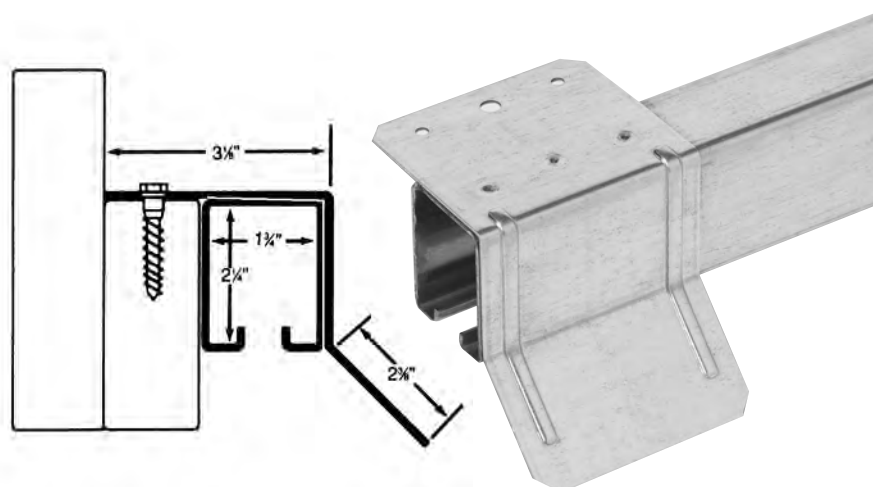

## #510 Track

Top mount track attaches with 1-1/2" ring shank neoprene washer nails. (5/16" lag screws or bolts may also be used if desired.) Combination mounting/flushing brackets are projection welded at the factory, and are approximately 24" on center. Available in 8, 10, 12, 14, 16, and 20 foot lengths.

# HEAVY DUTY TRACK SYSTEM

## #4 Heavy Duty Track (1000 lb. Capacity)

For doors 2-1/4" to 3-1/4" thick, weighing up to 1000 lbs. if brackets are spaced no more than 18" on center. (Double brackets - 12" o.c.) Extra heavy duty 13-gauge track with galvanized finish for long corrosion-free life. Available in **8, 10, and 12 foot lengths.**

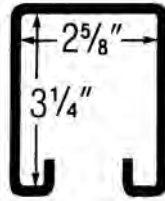

## Track Brackets

Brackets are made of heavy-duty 3/16" steel, with zinc-plated finish. Mounting holes accommodate 3/4" bolts or lag screws (not included).

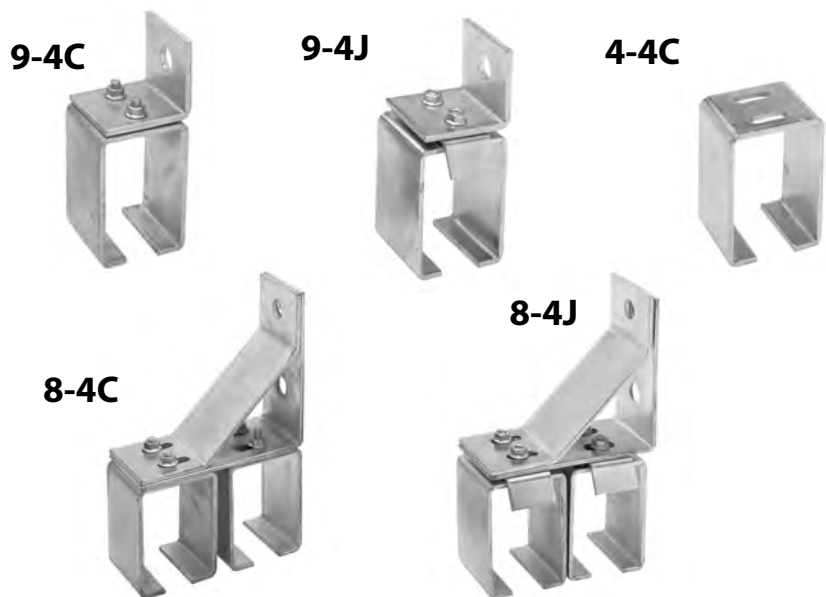

## Hangers/Trolleys

Made of heavy-duty 11 gauge galvanized steel, both are vertically and laterally adjustable. Wheels are 3" in diameter, 5/16" thick, and zinc plated. Bolt size is 5/8" x 11" - 5" long.

**251-S-1**  
(Hanger)

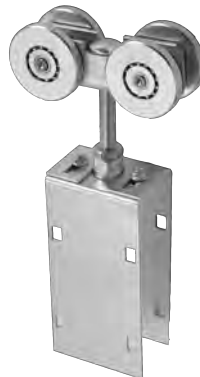

**251-S-1T**  
(Trolley)



# TRACK ACCESSORIES AND COVERS

## End Blinds

#2 Track End Blind snaps into bracket to keep track free from birds, weather and other obstructions. For use with #2 Track Brackets.



**2-EB**

### NEW!

Track end blind is to be used with #7 and #8 covered track. Bolt and nut included.



**7-8EB**

#4 Track End Blind is designed for use with Heavy Duty #4 Track Brackets.



**4-EB**

## Flashing Bracket

Flashing Brackets may be nailed over track to provide support for compatible flashing. Top Mount 10-FB Flashing Bracket is used with #10 and #510



**10-FB**

## Covers

### 510 Track Cover

Not manufactured by Western. See your local trim dealer.

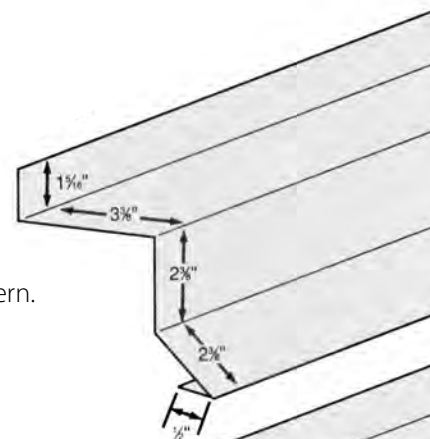

### 3 Track Cover

Not manufactured by Western. See your local trim dealer.

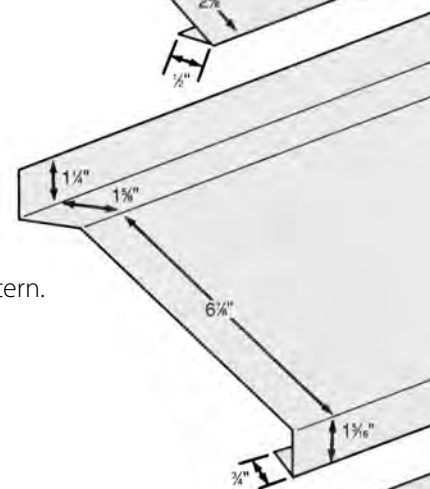

### 8-3C Track Cover

Not manufactured by Western. See your local trim dealer.

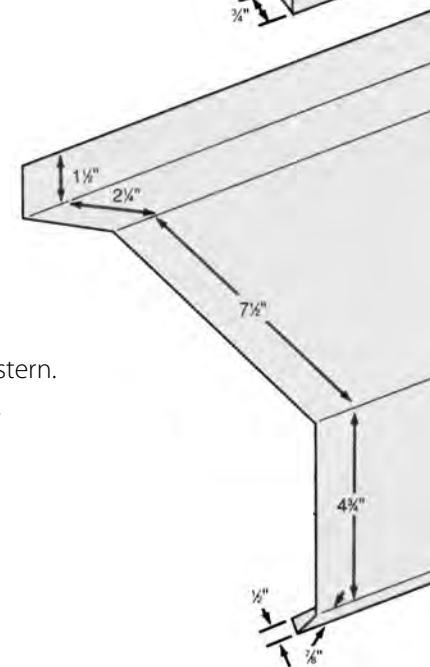

NOTE: All the above covers meet industry measurement standards and are compatible with most other track and hardware.



# SINGLE TRACK BRACKETS

## Face Mount

9-2C

### Track Bracket

Self clamping single track bracket, can also be used for joining two pieces of box track.



## Adjustable Face Mount

9-2S

### Track Bracket

Adjustable face-mount bracket has two mounting holes for 3/8" lag screws or bolts. Especially appropriate for **metal buildings**.



## Joint Bracket

9-2J

### Joint Bracket

A single splice bracket with two set screws to hold joining ends of track in alignment for long, smooth runs.



9-2SJ

### Joint Bracket

Special clamping feature allows firm track splices for long, smooth runs, when joining two pieces of track. Joint bracket has two mounting holes for 3/8" lag screws or bolts especially appropriate for **metal buildings**.



## Ceiling Mount

4-2C

### Track Bracket

For overhead track mounting.





# DOUBLE TRACK BRACKETS

## Track Bracket

8-2C

### Double Track Bracket

Adjustable face-mount bracket has two mounting holes for 3/8" lag screws or bolts. Especially appropriate for **wood header** board.



8-2S

### Double Track Bracket

Adjustable face-mount bracket has two mounting holes for 3/8" lag screws or bolts. Especially appropriate for **metal buildings**.

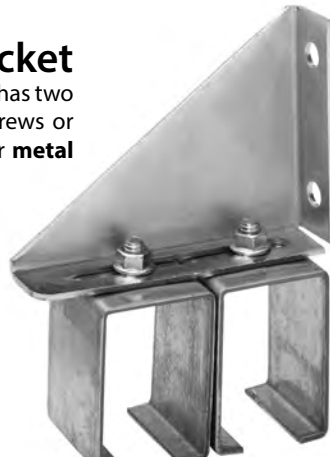

8-2SFB

### Double Track Bracket

Adjustable face-mount bracket has two mounting holes for 3/8" lag screws or bolts. The flashing bracket is pre-attached at the factory to accept a double track cover. Especially appropriate for **metal buildings**.

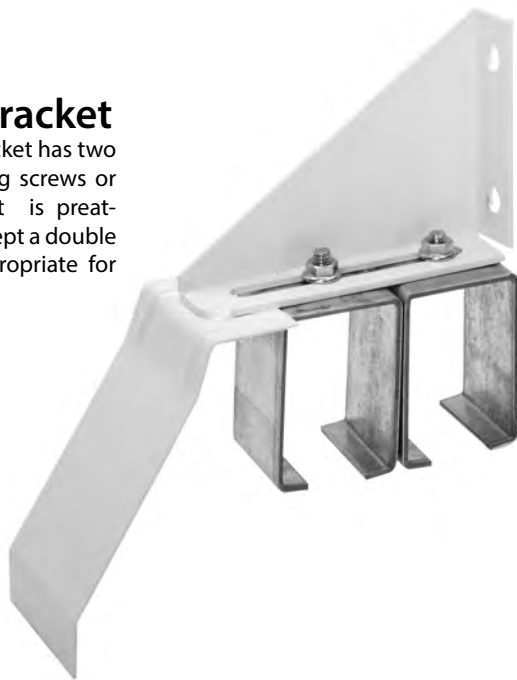

## Joint Bracket

8-2J

### Double Joint Bracket

Adjustable face-mount bracket has two mounting holes for 3/8" lag screws or bolts. Especially appropriate for **wood header** board, when joining two pieces of track.



8-2SJ

### Double Joint Bracket

Adjustable face-mount bracket has two mounting holes for 3/8" lag screws or bolts. Especially appropriate for **metal buildings**, when joining two pieces of track.



# HANGERS & TROLLEYS... FOR SMOOTH RUNNING DOORS

**Western** Hangers and Trolleys are designed for easy rolling and dependability, featuring heavy-duty stamped wheels and precision-machined axles. All exposed parts are made from heavy-gauge galvanized or zinc-plated steel. The standard hangers and trolleys feature oiled-for-life steel bearings with the most popular models, available in heavy duty ball bearings. Choose **RB** series for **ball bearings**.

## 100-HD

This one-piece apron door strap hanger is laterally and vertically adjustable. Comes with 6-5/16" - 2-1/2" carriage bolts for attaching door straps; supports door up to 400 lbs.



## RB-100-HD

Same as above with **ball bearings**.

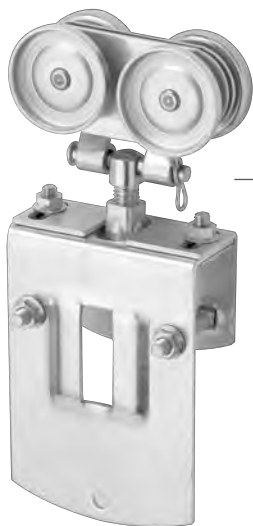

## RB-32-LB

This **ball bearing** apron hanger has vertical and horizontal adjustments. Flexible coupling between hanger and drop straps assures door will hang plumb. The connecting pin allows the drop strap to be mounted to the door before hanging, when required.

## 102-S1-L

Adjustable rigid bolt hanger for doors 1-1/2" to 2-3/8" thickness. Includes four 5/16" carriage bolts per pair.



## 102-S1-T

Vertically adjustable with a rigid bolt. Bolt is 1/2" x 4-1/2" with 2" thread and two hex nuts.



## RB-102-HD

This one-piece apron door strap is laterally and vertically adjustable with a rigid 1/2" x 4-1/2" straight bolt, **ball bearings**, and 6-5/16" - 2-1/2" carriage bolts.



## 107-L NEW!

Adjustable, pivot and swing-free action. Doors 1-1/2" to 2 3/8" thickness. Includes four 5/16" carriage bolts per pair.



### RB-107-L

Same as above with **ball bearings**.

## RB-309-T

The drop bolt installs vertically through the top frame member (wood or metal) of the door. This **ball bearing** trolley has vertical and horizontal adjustments. The horizontal adjustment bolt is easily accessible after installation. The connecting pin allows the drop bolt to be mounted to door before hanging, when required.



## 302-T

Popular bolt-through design speeds installation. Long 1/2" x 10" offset bolt can be used with a variety of door materials, and utilizes Western's original girt clip. This offset bolt offers a lateral adjustment and generous vertical adjustment.



## 307-T NEW!

This 1/2" x 9" offset bolt has two flat sides milled into the bolt for use with Western's **"Easy Lock"** Door System. The special washer has **8 holes** in it for easy adjustment for locking system in place (with a self tapping screw) once all adjustments have been made.



### RB-307-T

Same as above with **ball bearings**.

## RB-202-T

Designed for the woven wire industry, this two-wheeled **ball bearing** trolley features a 1/2" x 4 1/2" bolt for easy vertical adjustment with two flat spots machined into the bolt.



# SLIDING DOOR ACCESSORIES

## Latches



### 600 Jamb Latch

This 7" Jamb latch/snugger is used on the inside of jamb to secure sliding doors, and can be used for either right or left hand applications. The strike plate is lumber-fit for easy installation.

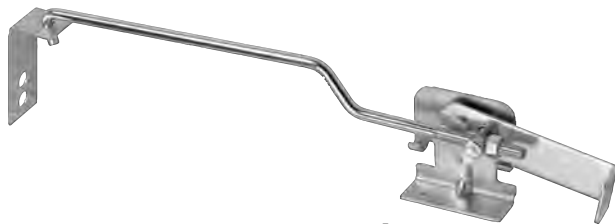

### 610 Center Door Latch

Easily and tightly secures bi-parting doors with cam-action latch. A strong bolt hooks at one end to fit strike plate; opposite end is threaded to allow adjustment of latch tension. For wood doors 1-1/2" or thicker.



### 620 Sliding Latch

Reversible, use right or left hand operation. Sturdy 1/2" x 8" solid steel bolt. Zinc plated. Add padlock by placing heavy staple or hasp in slotted handle. Includes fasteners.



### 630 Sliding Bolt Latch

Ideal for livestock/horse barns, this heavy duty 1/2" x 10" steel bolt doubles as a handle/pull, and may be latched at left or right. Mounting screws included and installation guide is on package label.

## Stay Rollers



### 585 Stay Roller

Wall mounted. Adjustable for doors 1-1/4" to 3-5/8" thick. Reversible, 2" non-marking plastic wheel. Frame is 3/16" zinc plated steel, 1-1/4" wide x 4-1/2" long.



### 780 Stay Roller

Wall mounted with 2" diameter non-marking plastic wheel. Adjustable and reversible for doors 1-1/2" to 2-1/2" thick. Frame is 1/8" thick, 3-1/2" wide, 4" long and zinc plated.



### 800 Stay Roller

This heavy duty stay roller is fabricated from 3/16" zinc plated steel, and adjust for doors 1" to 3-3/4" thick. The 2" non-marking plastic wheel is mounted on a sturdy 1/2" bolt.

## Door Pulls



### 50-3 Door Pull

This door pull is 1-1/4" wide and has a 6-5/8" overall length. Retains 1-3/4" deep clearance to allow use with gloved hand. Order 50-3 for zinc plated finish, 50-3W for white powder coated. 50-3B for black powder coated.



### 50-5 Door Pull

Extra heavy construction for use with heavy doors. With a 7-7/8" over-all length, 2" wide, 7/16" holes. Formed 1-3/4" deep to allow easy use, even with gloved hand. Order 50-5 for zinc plated finish or 50-5W for white powder coated finish.

# SLIDING DOOR ACCESSORIES

## Door Binders/Stops

### 537 Single Binder/Stop

Offset is 2" x 3-1/4". Overall length is 7" and is fabricated from 3/16" x 1-1/2" zinc plated steel. Holes accept 3/8" bolts or lag screws . (not included.)



### 550 Adjustable Door Binder/Stop

Heavy duty, adjustable for single side or bi-parting doors. Widths 2-1/2" to 3-1/8" thick.



### 540 Door Binder/Stop

For 2" doors, made from rugged zinc-plated steel and ribbed to increase strength. Holes accept 5/16" bolts or lag screws (not included).



### 560 Jamb Mount Door Stop

2-1/2" x 8-1/2" galvanized steel unit extends from jamb to stop and hold doors in the open or closed position.



### 545 Adjustable Door Guide/Stop

This adjustable guide may be expanded in width for doors from 2-1/2" to 6" thick. Curved surface gives natural lead-in. This door guide also mounts sidewise for use as a stop. Easy to install, available in powder-coated white finish.



## Miscellaneous

### 618 Cane Bolt

1/2" diameter rod x 18" in length zinc plated. Fancy mounting brackets and screws included.

### 624 Cane Bolt

5/8" diameter rod x 24" in length zinc plated. Fancy mounting brackets and screws included.

### 900 Chain Snugger

Ring and hook simply secure a chain to desired length for holding bi-parting sliding door together. Designed for use with clad wood-frame doors.



### 528 Stake Holder

Ideal for vertical post applications. This design prevents tapered 2 x 4 from sliding thru holder. Heavy duty steel construction. (1-3/4" x 3")



# ROUND TRACK OPTIONS

Western's 600-lb. capacity round track will provide years of smooth, easy gliding operation. The self-cleaning design and corrosive resistant **14 gauge** galvanized construction features are available in track slotted with a full keyway (#3 track), in track with brackets attached at the factory for top mounting (#3A), and in track with factory-attached brackets for face mounting (#3B). Slots/brackets are positioned 12" from end, 24" on center, on track sections in your choice of the following lengths for all three track products: 6, 8, 10, 12, 14, 16, 20 and 24 feet. In addition to offering track sections with factory mounted brackets, Western has engineered the keyway slots in its track with two-way movement options, allowing for easy "knock-on" application in the field. Knock all brackets in same direction (left or right) until the last bracket, where direction is reversed to make a positive lock.

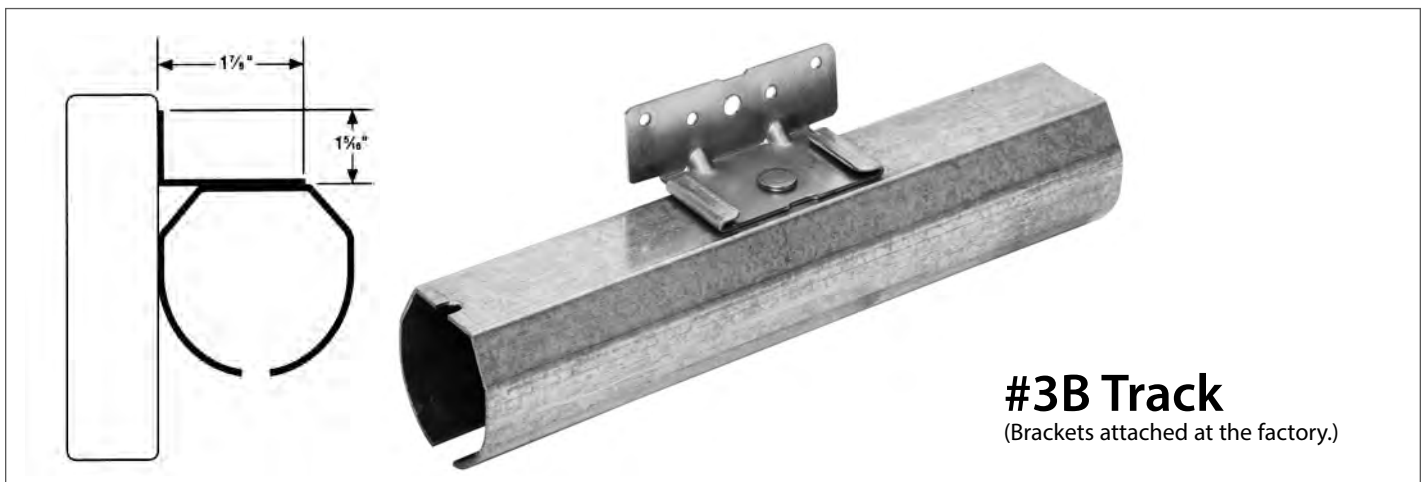
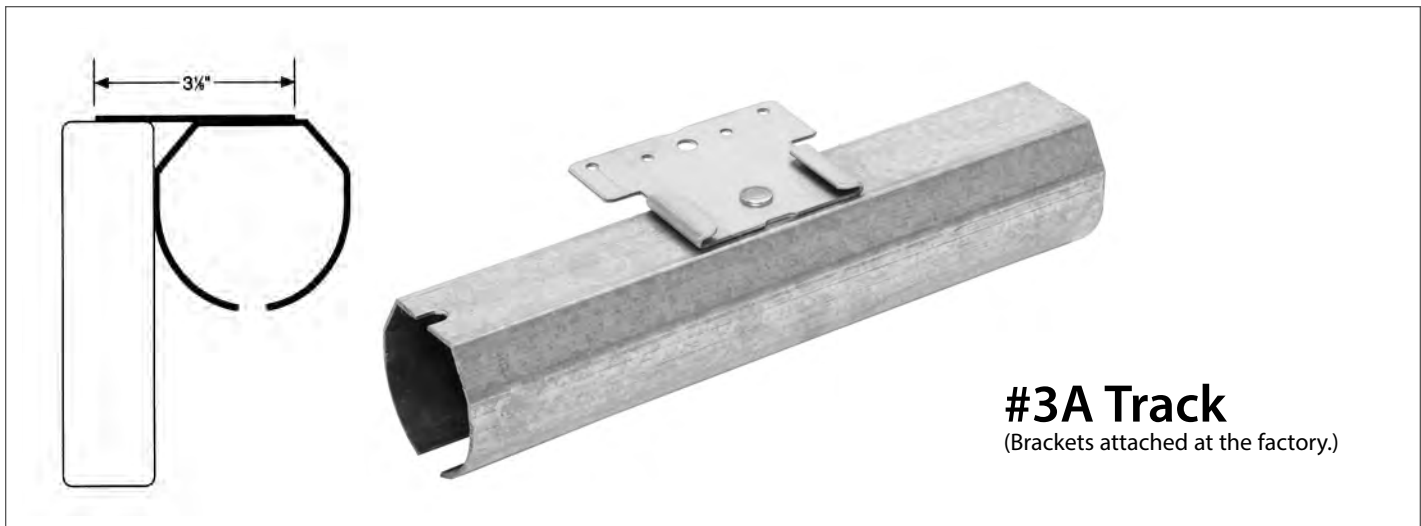
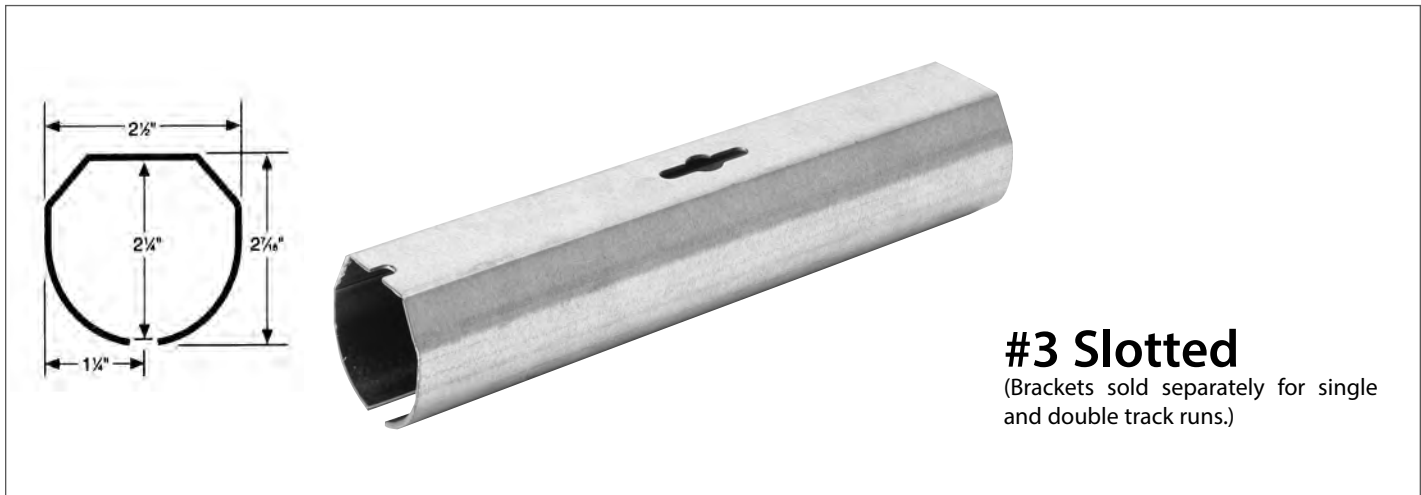

# SINGLE AND DOUBLE TRACK BRACKETS



## 8-3C Bracket

Double track bracket (face mount), bolts included. Use with #3 slotted track.



## 8-3CFB Bracket

Double track bracket. Same as 8-3C but with Flashing Bracket pre-attached at factory to accept a Double Track Cover and is used with #3 slotted track. (white powder coated. 600lb. total capacity)



## 3-1PC Bracket

For use with #3 slotted round track. Rivets fit through key-way slots in each track section, allowing track, brackets, and cover to be joined as a single unit.



## 3-AC

This slide-on bracket top mounts for use with #3 slotted track.



## 3-BC

This slide-on bracket face mounts for use with #3 slotted track.



**NEW!**

## 3-SLB

Bracket can be used as a ceiling mount bracket or with other angle mounting brackets.

## SC-3 HD

Heavy-duty track splice collar. To be used with the 3-ASB and 3-ADB brackets. (#3 slotted track only.)



## 3-ASB-FB Adjustable Single Bracket

Wall mounted, and used at 12" to 18" intervals to hang track to the side of the building. Can be used with 1 1/2" and 3 1/2" doors.

Available 3-ASB without flashing bracket.



## 3-ADB-FB Adjustable Double Bracket

Wall mounted, and used at 12" to 18" intervals to bring double runs of track to the side of the building for by-pass installation.

Available 3-ADB without flashing bracket.

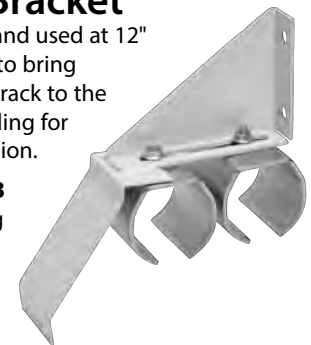

## Accessories



**SC-3**  
Round Track splice collar.



**3-FB**  
Round Track Flashing Bracket taps in for 1 1/2" doors.

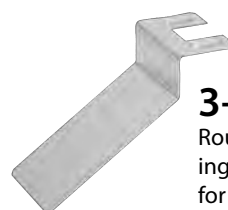

**3-FB 3.5**  
Round Track flashing bracket taps in for 3 1/2" doors.

**NEW!**



**3-EB**  
Round Track End Blind with Mounting Bolt.



# PLASTIC WHEEL TROLLEYS/HANGERS

## Plastic Wheels with Bronze Bushings



### 103-T

Features pivot and swing action with a 1/2" x 4" bolt, and two nuts.



### 203-L

Adjustable, pivot and swing action with single strap apron. For doors 1-1/2" to 2-3/8" thickness. Includes six 5/16" carriage bolts per pair.



### 303-T

A 1/2" x 9" offset bolt adjusts easily and uses Western's original girt clip. Generous vertical adjustment accommodates a variety of door materials.

## Plastic Wheels with Ball Bearings



### RBP-103-T

Features pivot and swing action. With a 1/2" x 4" bolt, and two nuts. Plastic wheels with **ball bearings**.



### RBP-203-L

Adjustable, pivot and swing action with single strap apron. For doors 1-1/2" to 2-3/8" thickness. Includes six 5/16" carriage bolts per pair. Plastic wheels with **ball bearings**.



### RBP-303-T

A 1/2" x 9" offset bolt adjusts easily and uses Western's original girt clip. Generous vertical adjustment accommodates a variety of door materials. Plastic wheels with **ball bearings**.

# STEEL WHEEL TROLLEYS/HANGERS

## Steel Wheels with Ball Bearings



### RB-103-T

Features pivot and swing action with a 1/2" x 4" bolt, and two nuts. Steel wheels with **ball bearings**.



### RB-203-L

Adjustable, pivot and swing action with single strap apron. For doors 1-1/2" to 2-3/8" thickness. Includes four 5/16" carriage bolts per pair. Steel wheels with **ball bearings**.



### RB-303-T

A 1/2" x 9" offset bolt adjusts easily and uses Western's original girt clip. Generous vertical adjustment accommodates a variety of door materials. Steel wheels with **ball bearings**.

### DTRB-303-T

Double truck trolley assembly – steel wheels with **ball bearings** and 9-1/2" bolts for use on doors weighing **500-600 lbs. and 16' and larger**. MUST use two pair per door. Sold two pair per carton.

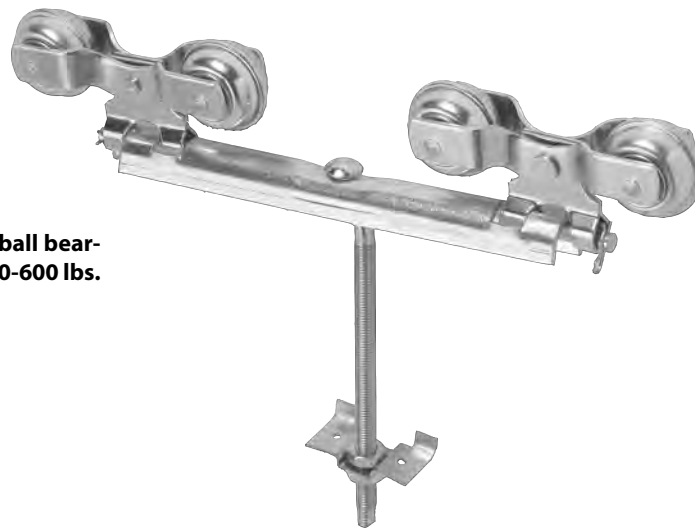

# 1 1/2" SLIDING DOOR FRAMES

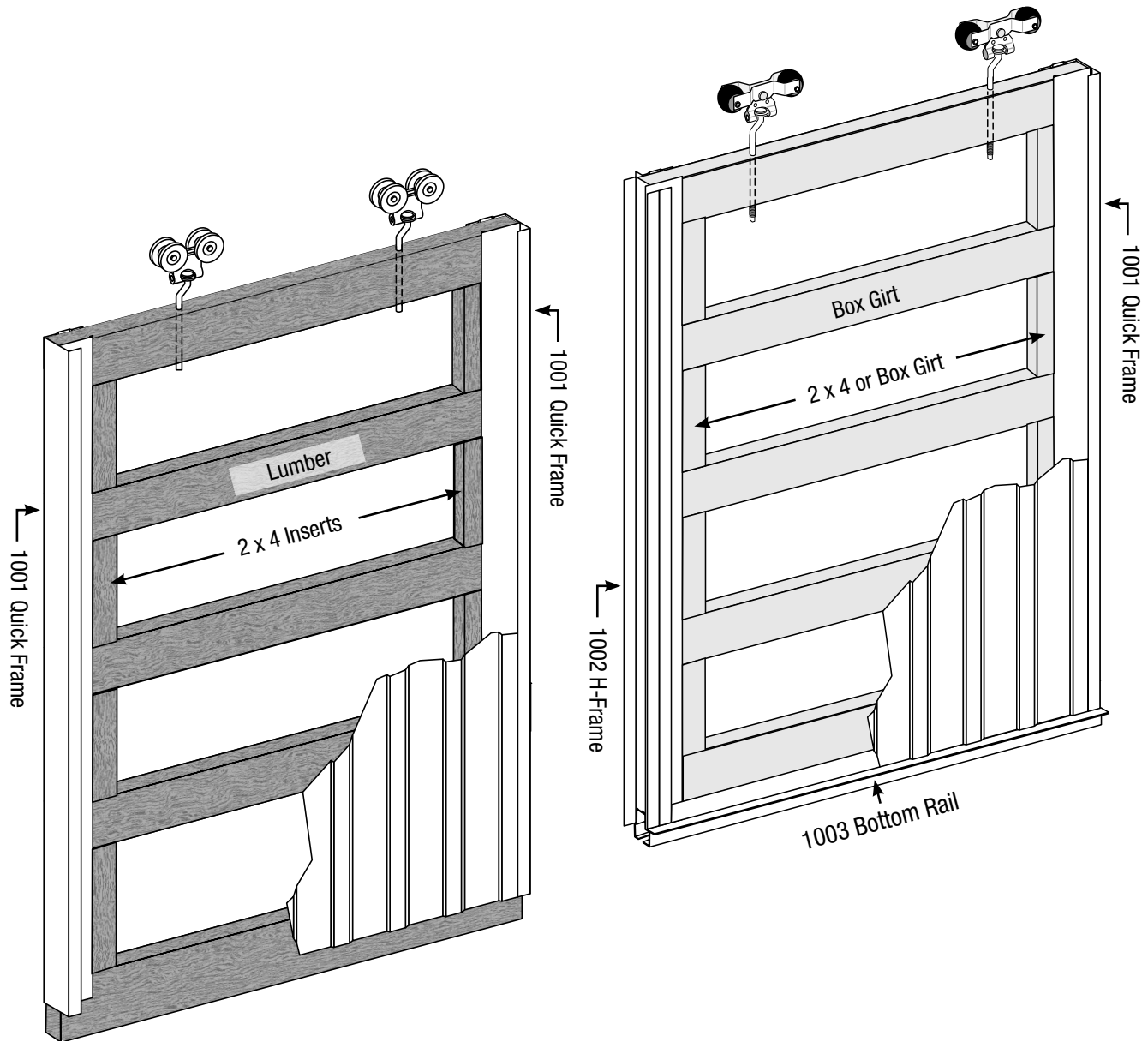

## SLIDING DOOR FRAMES

White Steel or White Aluminum Quick Frames can be assembled with standard 2 x 4 lumber or galvanized Steel Box Girts as horizontals. **Western Products** recommends spacing these horizontals approximately 24" to 28" on center. Wood or steel inserts can be placed inside the vertical channel between each horizontal. Inserts should be permanently attached with screws, becoming part of the frame. This is suggested to help prevent damage to the doors in windy conditions.

# 1-1/2" SLIDING DOOR FRAMES

## White Aluminum

### 1001 White Aluminum Quick Frame

Is lumber fit for standard 2 x 4 or 2 x 6 and provides smooth, safe sides for door openings. Packaged in 10 piece bundles per order, available in 8, 10, 12, 14, 16', 18' and 20' lengths.

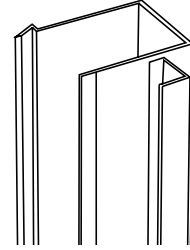

### 1002 White Aluminum H-Frame

Designed for use with bi-parting doors, provides concealed mating between units covering both door edges. Packaged in 10 piece bundles per order, available in 8, 10, 12, 14, 16', 18' and 20' lengths.

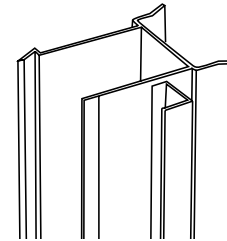

### 1003 White Aluminum Bottom Rail

Attaches to bottom of door and accepts the #64 Rail Guide to firmly anchor and guide door along building during operation. Order for doors 1-1/2" thick. Available in 8, 10, 12, 14, 16, 18, and 20' lengths.

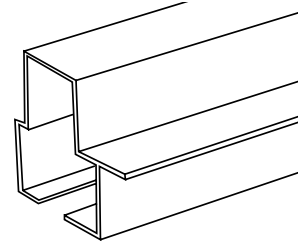

### 1005 White Aluminum Bottom Rail

Mounts on face of **wood bottom** rail and provides a smooth surface for a stay roller. Available in 8, 10, 12, 14, 16, 18, and 20' lengths.

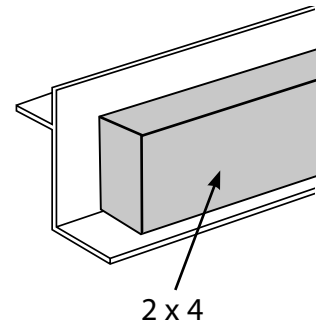

## Box Girt/Horizontal

### 2004 Galvanized Steel Girt

Made from 20 gauge galvanized steel (1-1/2" x 3-1/2" lock seamtube). Can be used in place of wood horizontal girts to eliminate warping, bowing, and cracking of door panels. Weight is 1.3 lbs./ft. Available in 6' - 24' lengths.

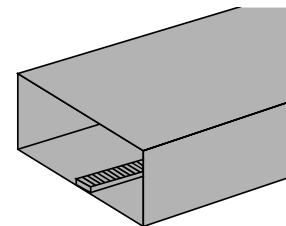

# BOTTOM GUIDE SYSTEMS AND ACCESSORIES

## #60 Guide Rail Bracket

For use with #64 Guide Rail. Slotted hole in each leg allows both lateral and vertical adjustments. Bolts and nuts included.



## #68 Single Door Stop

For use with #64 Guide Rail System. Stops door and prevents from disengaging with guide rail.



## #68 DDS Double Door Stop

For use with #64 Guide Rail. Slotted hole in each leg allows both lateral and vertical adjustments. Bolts and nuts included.

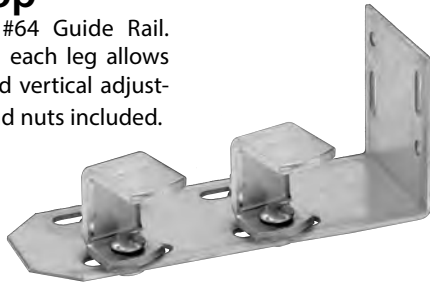

## #60 DGRB Double Guide Rail Bracket

For use with #64 Guide Rail. Slotted hole in each leg allows both lateral and vertical adjustments. Bolts and nuts included.

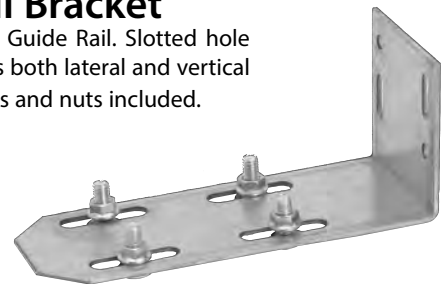

## #64 Guide Rail

Fabricated from 16 gauge galvanized steel and mounts with #60 brackets. Engages the bottom door guides to hold the door in place and prevent wind damage. Available in 4', 6', 8' and 10' lengths.



# BOTTOM GUIDE SYSTEMS AND ACCESSORIES

## Optional Hardware

### #520 Center Guide/Stop

Installs on 6 x 6 post or in concrete, in the center of split doors or a large single door. For use in pairs.

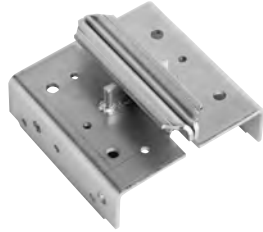

### #790 Center Door Guide

Adjustable for single sliding doors 1-1/2' to 3-1/4' thick. Install as shown with screws and lead anchors after final adjustments have been made to level and plumb the door. **(Fasteners included)**

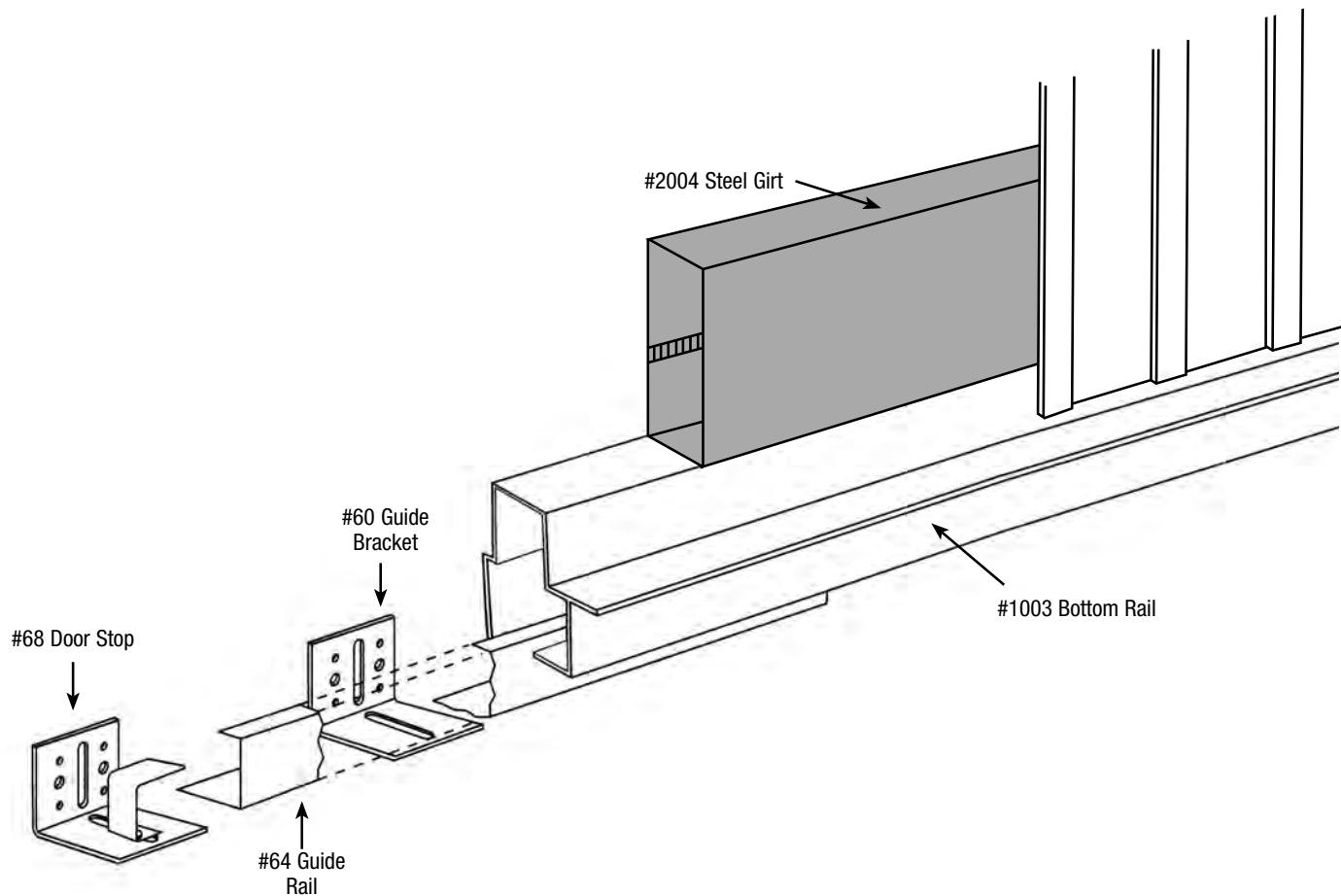

# 3-1/2" SLIDING DOOR FRAME FOR "BIG DOORS"

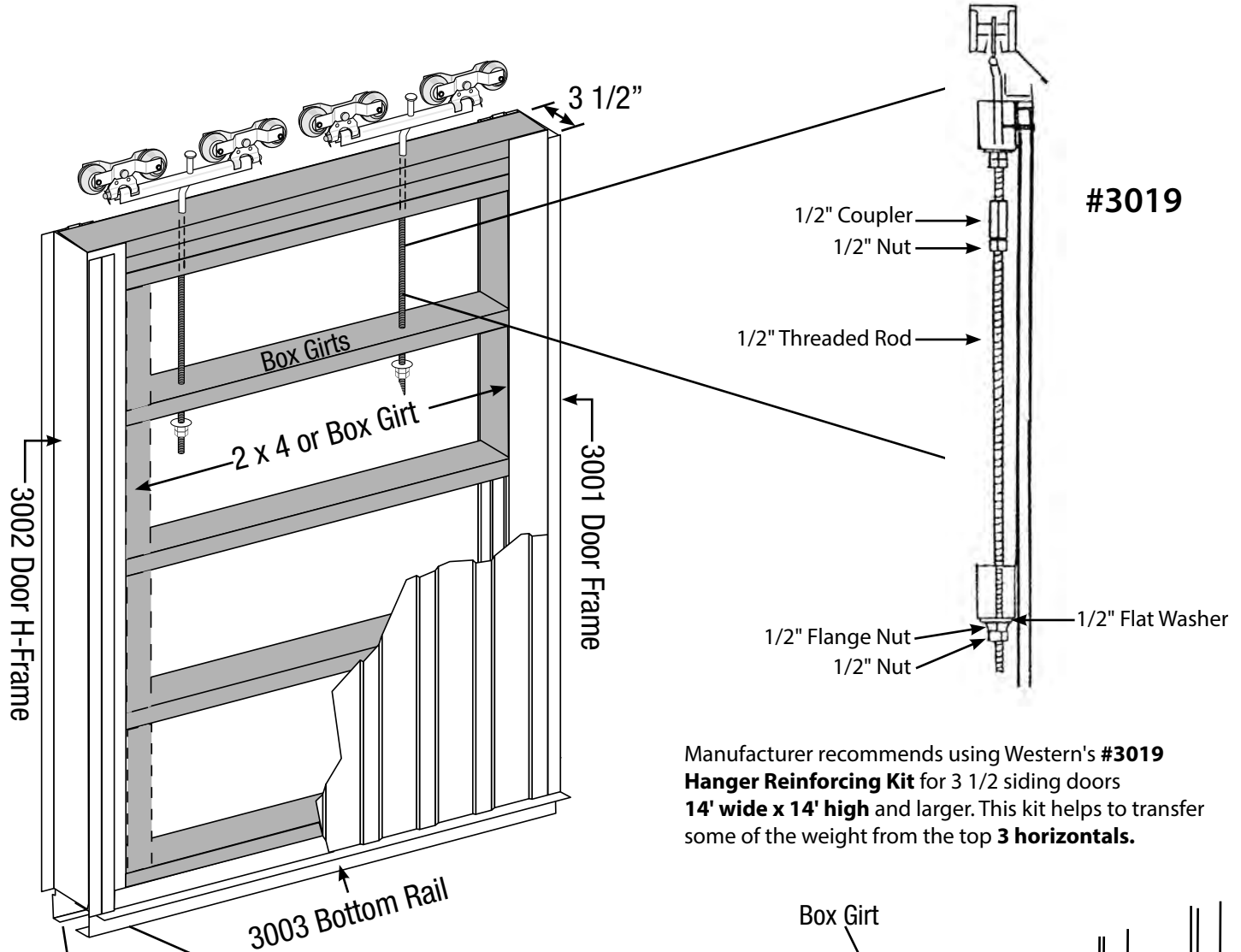

Manufacturer recommends using Western's **#3019 Hanger Reinforcing Kit** for 3 1/2 siding doors **14' wide x 14' high** and larger. This kit helps to transfer some of the weight from the top **3 horizontals**.

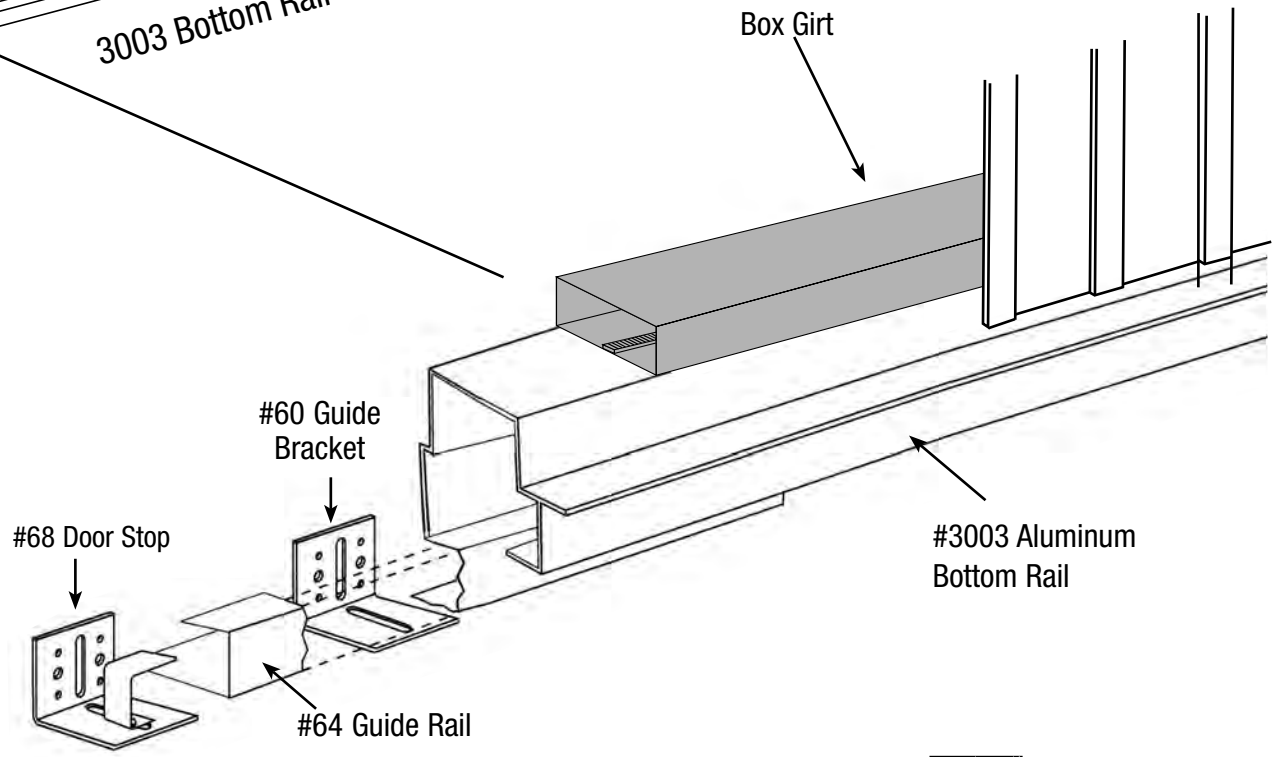



# 3-1/2" SLIDING DOOR FRAMES

## White Aluminum

### 3-1/2" SLIDING DOOR FRAMES WITH STEEL BOX GIRTS

White Aluminum Door Frames can be assembled with (20 gauge) galvanized Steel Box Girts as horizontals. Western recommends spacing these horizontals approximately 24" on center. Steel inserts should be placed inside the vertical channel between each horizontal. Inserts should be permanently attached with screws, becoming part of the frame. This is suggested to help prevent damage to the doors in windy conditions. **Manufacturer recommends using Western's #3019 Hanger Reinforcing Kit for 3 1/2 siding doors 14' wide x 14' high and larger.**

#### 3001 3-1/2" White Aluminum Door Frame

Is lumber fit (turned to the 3-1/2" side) for standard 2 x 4 wood or our steel box girts. Packaged in pieces, and bundled per order. Available in 12', 14', 16' and 18'.

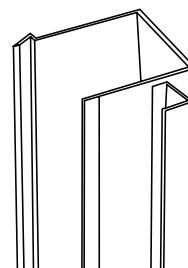

#### 3002 3-1/2" White Aluminum Door H-Frame

Designed for use with bi-parting doors, provides concealed mating between units, covering both door edges. Packaged in pieces, and bundled per order. Available in 12', 14', 16' and 18'.

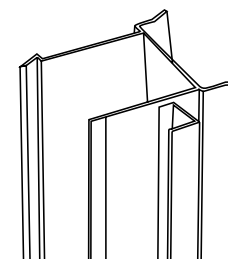

#### 3003 3-1/2" White Aluminum Bottom Rail

Attaches to bottom of door frame and accepts the #64 Guide Rail to firmly anchor and guide the door along the building during operation. Packaged in pieces, and bundled per order. Available in 8'-20' lengths.

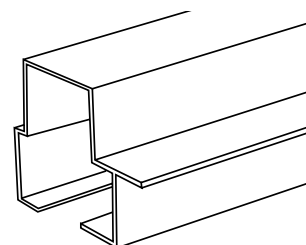

# 1001-WV White Vertical with Tabs

THIS ALL STEEL WHITE DOOR FRAME IS MANUFACTURED FROM 16 GAUGE GALVANIZED MATERIAL AND POWDER COATED WHITE

BUILT-IN FASTENERS ARE PRE-PUNCHED INTO THE VERTICAL MEMBER. JUST BEND THE KEYS DOWN INTO MATCHING HOLES PROVIDED IN THE LATERAL, DEVELOPING A SQUARE, TIGHT, PERMANENT STEEL DOOR FRAME.

Call Western for pricing and available sizes from **8' wide x 8' high** up to **20' wide x 16' high**. Bulk packed per order.

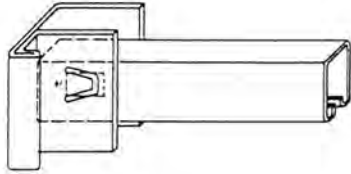

1. Align key over slots in cross members.

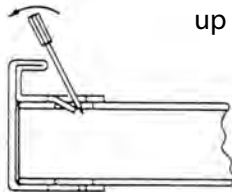

2. Insert screwdriver blade to start key.

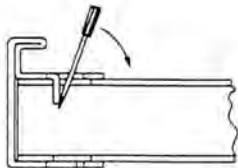

3. Bend key halfway, then square up frame.

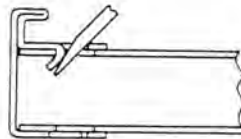

4. Lock key permanently

## To Shorten Door Lateral

Cut off desired amount and replace the square hole lost in the cut-off with 7/8 in. Diameter round hole.

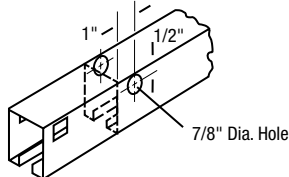

## To Shorten Door Vertical

Extra keys  
Allow shortening in 1 1/2". Increments up to 12 in.

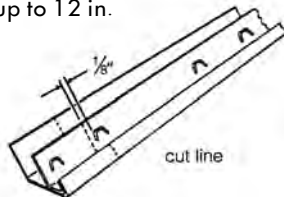

#68 Door Stop

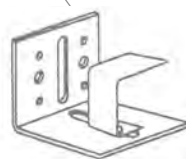

White Steel Vertical

#60 Guide Bracket



Steel Lateral

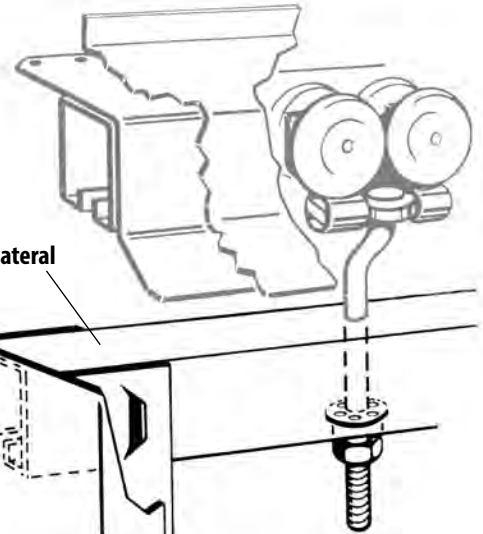

#64 Guide Rail

**NOTE:** FOUR KEYS (AT TOP) ARE PROVIDED IN VERTICALS TO BE USED IF A SHORTER HEIGHT IS REQUESTED. THIS WOULD BE THE TOP OF THE DOOR. FOUR KEYS ARE PROVIDED IN THE VERTICAL SO THAT BOTTOM LATERAL MAY BE USED AS A GUIDE IF DESIRED OR SIMPLY FLUSH MOUNTED.

# EASY LOCK DOOR SYSTEM

## HEAVY DUTY STEEL FRAME IS MANUFACTURED FROM 14 GAUGE AND 16 GAUGE GALVANIZED MATERIAL

BUILT-IN FASTENERS ARE PRE-PUNCHED INTO THE VERTICAL MEMBER. JUST BEND THE KEYS DOWN INTO MATCHING HOLES PROVIDED IN THE LATERAL, DEVELOPING A SQUARE, TIGHT, PERMANENT STEEL DOOR FRAME.

Call Western for pricing and available sizes from **8' wide x 8' high** up to **20' wide x 16' high**. Bulk packed per order.

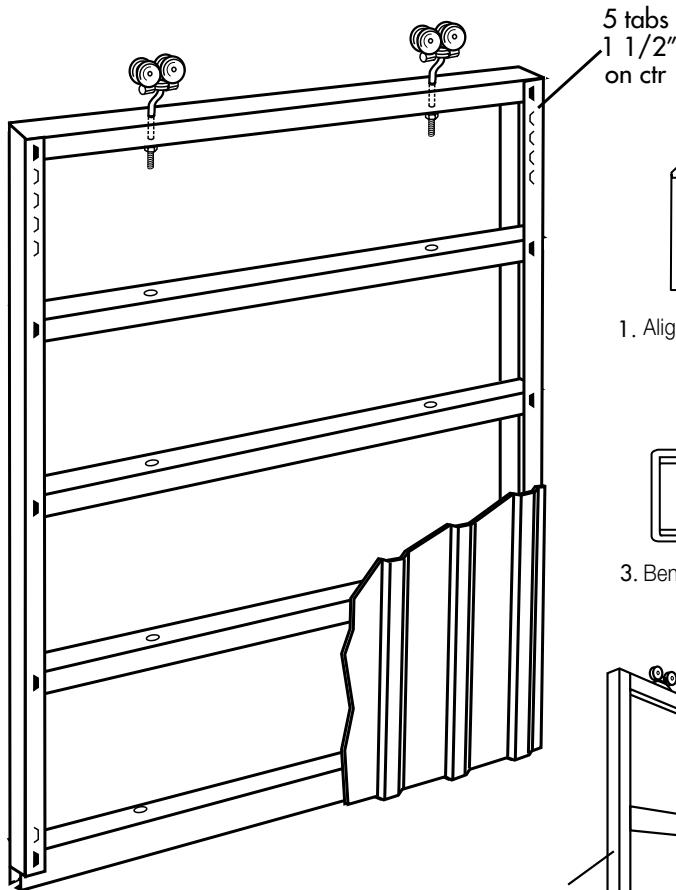

5 tabs  
1 1/2"  
on ctr

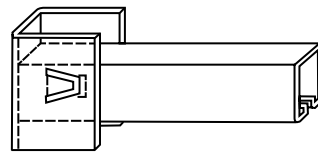

1. Align key over slots in cross members.

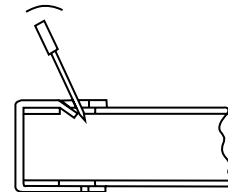

2. Insert screwdriver blade to start key.

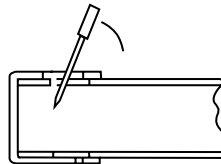

3. Bend key halfway, then square up frame.

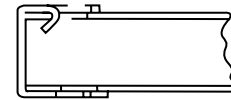

4. Lock key permanently

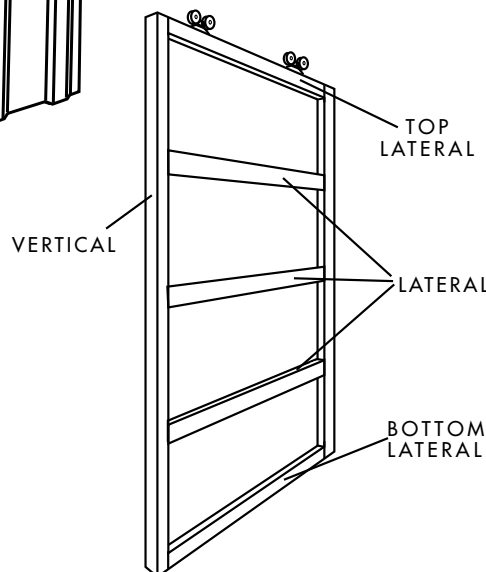

### To Shorten Door Lateral

Cut off desired amount and replace the square hole lost in the cut-off with 7/8 in. Diameter round hole.

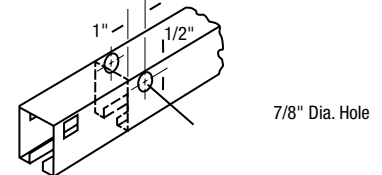

7/8" Dia. Hole

### To Shorten Door Vertical

Extra keys  
Allow shortening in 1 1/2". Increments up to 12 in.

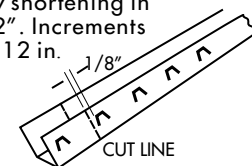

CUT LINE

**NOTE:** FIVE KEYS (AT TOP) ARE PROVIDED IN VERTICALS TO BE USED IF A SHORTER HEIGHT IS REQUESTED. THIS WOULD BE THE TOP OF THE DOOR. TWO KEYS ARE PROVIDED IN THE VERTICAL SO THAT BOTTOM LATERAL MAY BE USED AS A GUIDE IF DESIRED OR SIMPLY FLUSH MOUNTED.

# Horse Stalls

Western Horse Stalls are not only attractive, but tough as nails with maximum ease of assembly. The Western **"Flexi-Stall"** is engineered to provide the ultimate in design, flexibility and safety for your horses.

The versatility of our **"Flexi-Stall"** allows you to mix and match components to customize your stall to fit your specific needs. Safety has also been engineered into every stall, with no exposed edges for horses to chew, no hardware or sharp edges to rub against and no protruding objects to step on.

Western then finishes each component with an attractive black powder coating to accent the beauty of your stalls.

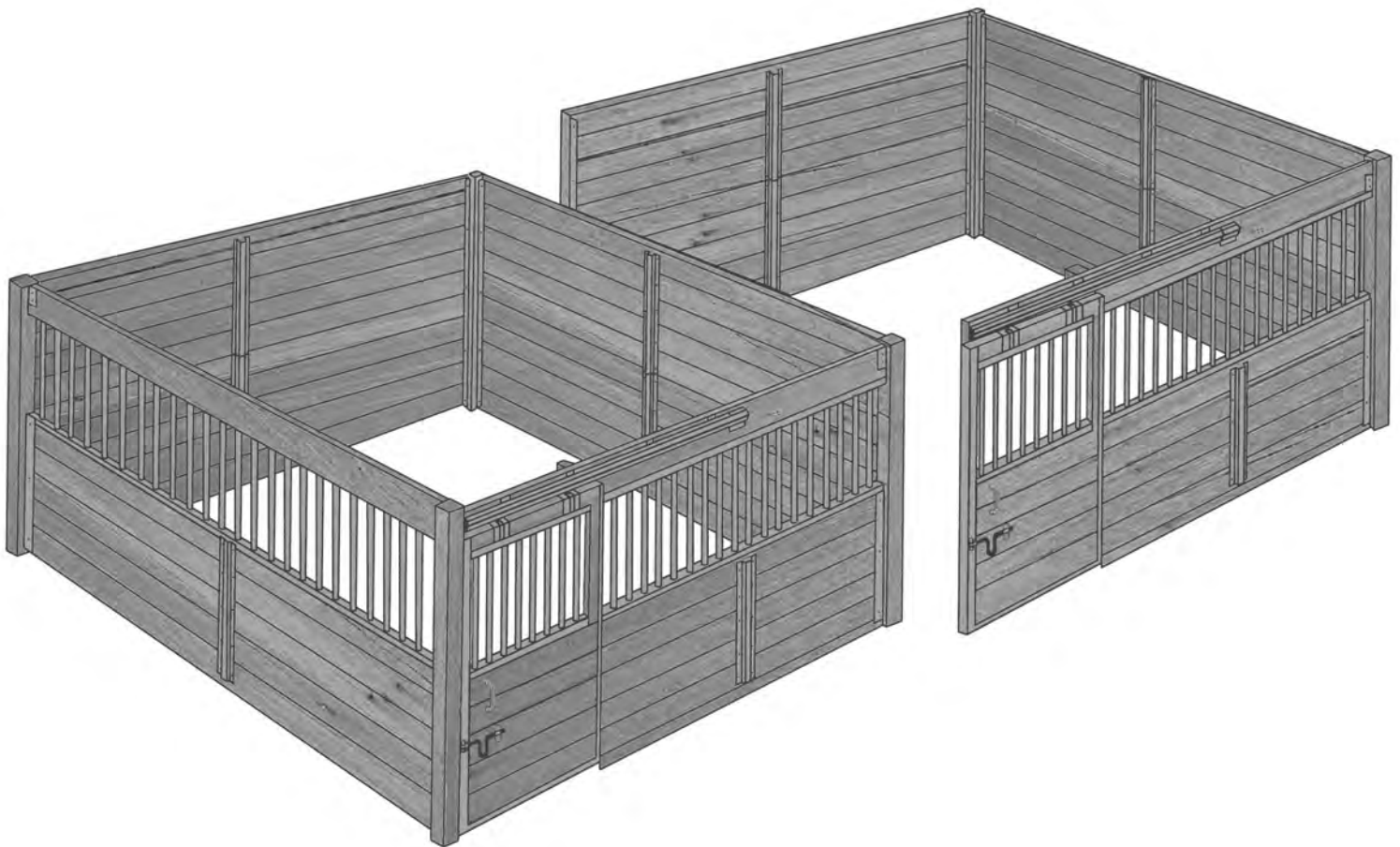

Versatile, durable, attractive and affordable...**Western Horse Stalls.**

# Door and Wall Systems

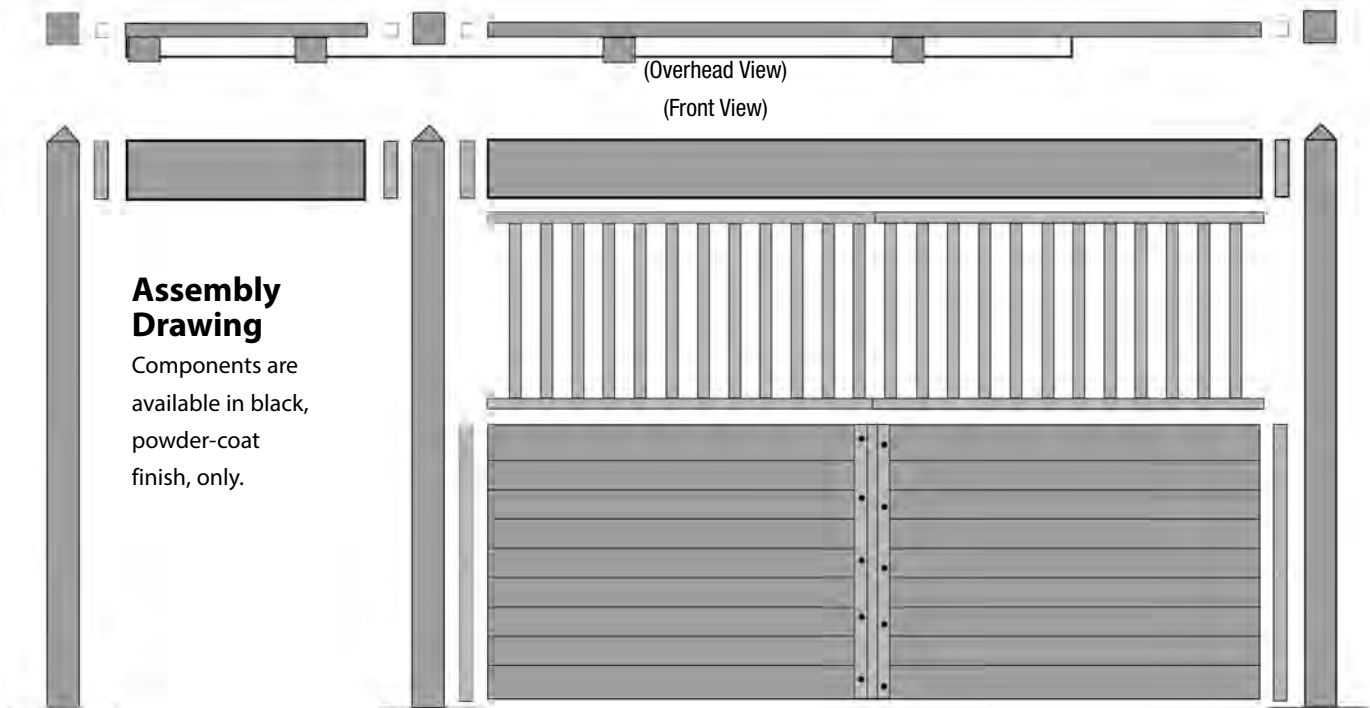

## Assembly Drawing

Components are available in black, powder-coat finish, only.

WESTERN'S Stall Kits may be used in a wide range of fabricating techniques. This is just one example of how to build a front wall. (Measurements must be calculated in the field.)

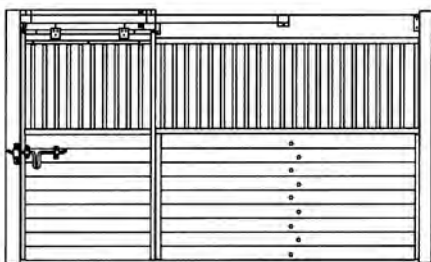

## Front Wall System (Door Not Included)

### 10' Front (80010)

### 12' Front (80012)

Door dimensions are 48" wide, 86" high. Overhead clearance must be at least 94 1/2" to accommodate the door, trolley, and track. System comes complete with the following:

- |  |                           |
|--|---------------------------|
| 2 Grillwork Sections                             | 2 End Channels (80045)    |
| 10' front includes 1-24" (80240) & 1-48" (80480) | 4 Header Channels (80006) |
| 12' front includes 2-48" (80480)                 | 1 Wall Brace (84545)      |

*(Additional wood materials required:)*

- |                              |                              |
|------------------------------|------------------------------|
| 10' Front Wall               | 12' Front Wall               |
| 8 2" x 6" x 6'               | 9 2" x 6" x 8'               |
| 1 2" x 12" x 10' track board | 1 2" x 12" x 12' track board |

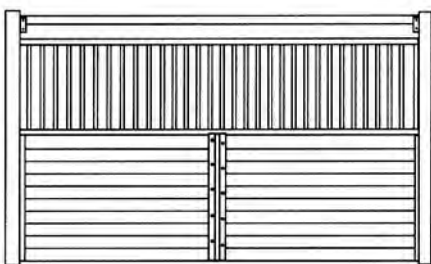

## Side Wall System

### 10' (81048)

### 12' (81248)

System comes complete with the following:

- |                               |                           |
|-------------------------------|---------------------------|
| Grillwork Sections            | 12' front includes        |
| 10' front wall includes       | 3-48" (80480)             |
| 2-48" (80480) & 1-24" (80240) | 2 End Channels (80045)    |
|                               | 2 Header Channels (80006) |
|                               | 1 Wall Brace (84545)      |

*(Additional wood materials required:)*

- |                          |
|--------------------------|
| 11 2" x 6" x 10' for 10' |
| 11 2" x 6" x 12' for 12' |

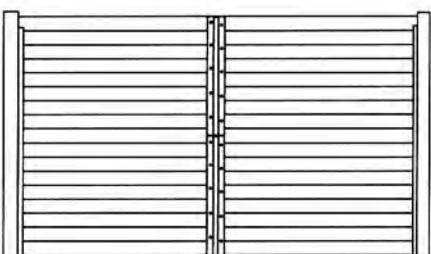

## Partition or Rear Wall System (80445)

System comes complete with the following:

- |                        |                       |
|------------------------|-----------------------|
| 4 End Channels (80045) | 2 Wall Braces (84545) |
|------------------------|-----------------------|

*(Additional wood materials required:)*

- |  |
|--|
| 17 2" x 6" equal to desired wall length. |
|--|

# SLIDING DOOR SYSTEM

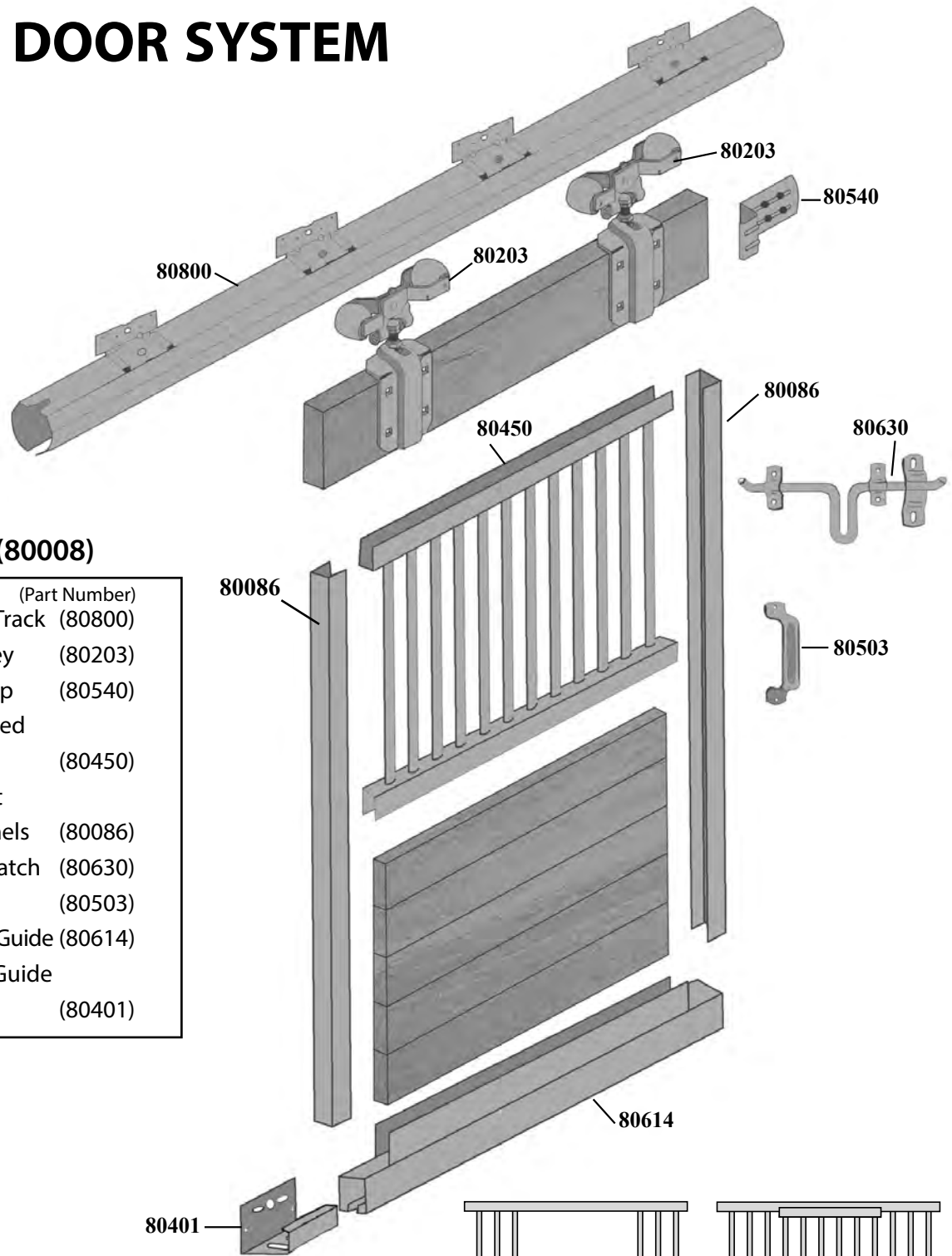

## Door Kit (80008)

	(Part Number)
1	8' #3B Round Track (80800)
1	pr. 203-L Trolley (80203)
1	#540 Door Stop (80540)
1	45" x 36" Welded Door Grille (80450)
2	86" Lumber Fit Vertical Channels (80086)
1	#630 Sliding Latch (80630)
1	50-3 Door Pull (80503)
1	4' #61 Bottom Guide (80614)
1	#401 Bottom Guide Retainer (80401)

## Western's Drop-Down Door Grille (80350)

Features 1" round 14 ga. tubing welded 3" o/c., in 14 ga. channels that are lumber fit for 2 x 6 or 2 x 8 standard lumber. Available in a 36" x 45" section, with a 23" x 35" opening and is black powder coated.

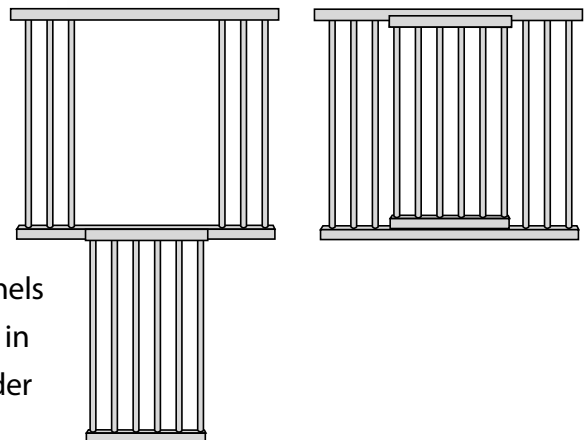

# HORSE STALL KIT, ACCESSORIES

## SwingOut Utility Door (82022)

Made of heavy duty 12 gauge steel mounted on a sturdy angle iron frame. Accommodates a wide variety of feeders, buckets and bucket holders. Can be installed to swing out from left or right by simply inverting the frame. Latch is designed so that the door cannot be opened from the inside. Outside dimensions are 24-3/4" high x 22-1/2" wide. **(Bucket not included.)**

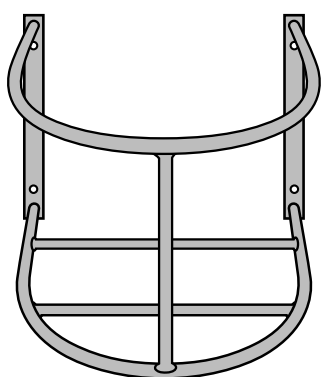
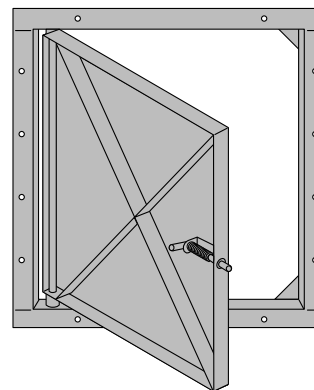

## Bucket Holder (82032)

Constructed of 1/2" round steel bar stock welded to 1" wide 11 gauge mounting plates with four holes for rigid mounting. Inside dimensions are 12-1/2" wide x 12-1/2" deep x 11" high. **(Fasteners not included.)**

## SwingOut Hay/Grain Feeder (82448)

Our best feeder, this front wall mounted feeder is fully reversible by switching hinge pin for left or right side mounting. Hay rack provides ample room for a generous flake. Welded angle supports for mounting plastic corner bucket. **(Bucket not included.)** Powder coated black with a #630 sliding latch included.

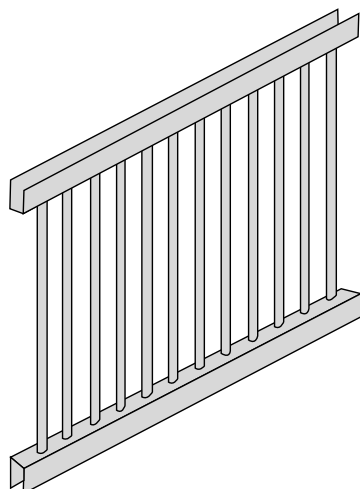
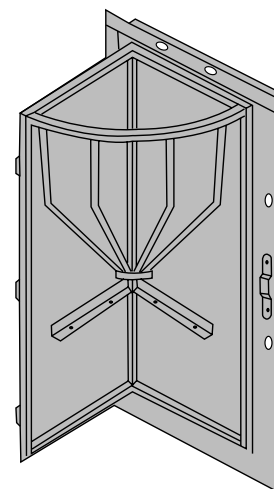

## Front Wall Grille

**24" (80240)**

**48" (80480)**

Features 1" round 14 ga. tubing welded 3" o/c., and 14 ga. channel-lumber fit for 2 x 6 or 2 x 8 standard lumber. Black powder coating. Available in 36" x 48" and 36" x 24" sections.



# MERCHANDISING PROGRAM

Western Products' displays are customer oriented for self-service. These boards are light weight and can be easily hung from the ceiling, or mounted on a back wall. They help your customer locate and select needed items.

**WESTERN HORSE STALLS**

**Partition Kit**

- 4 - End Channels
- 2 - Wall Braces with Assembly Fasteners

**Wall Kits**

**10'**

- 2 - 48" Grille Sections
- 1 - 24" Grille
- 2 - End Channels
- 2 - Header Channels
- 1 - Wall Brace with Assembly Fasteners

**12'**

- 2 - 48" Grille Sections
- 2 - End Channels
- 2 - Header Channels
- 1 - Wall Brace with Assembly Fasteners

**Front Wall**

**10'**

- 1 - 48" Grille Section
- 1 - 24" Grille Section
- 4 - Header Channels
- 2 - End Channels
- 1 - Wall Brace with Assembly Fasteners

**12'**

- 2 - 48" Grille Sections
- 2 - End Channels
- 4 - Header Channels
- 1 - Wall Brace with Assembly Fasteners

**Door Kit**

- 1 - 8' Round Track
- 1 - Pair of Rollers
- 1 - 45" x 34" Grille Section
- 2 - 86" Lumber Fit Vertical Channels
- 1 - Door Stop
- 1 - Sliding Latch
- 1 - Door Pull
- 1 - 4" Bottom Guide
- 1 - Bottom Guide Release

**WESTERN PRODUCTS OF INDIANA**

**SLIDING DOOR HARDWARE**

- 2 Box Track
- 9-2C Self-Cleaning Bracket
- 100-2B Axle Roller
- 2-EB End Block
- 100-2B Axle Roller
- 107-L Roll Roller
- 620 Sliding Latch
- 620 Sliding Latch
- 630 Sliding Bolt Latch
- 630 Sliding Bolt Latch
- 100-5 Door Pull
- 780 Stay Roller
- 1000 Heavy Duty Stay Roller
- 9-2C Double Track Bracket
- 640 Door Stop

**WESTERN PRODUCTS OF INDIANA**

**SLIDING DOOR HARDWARE**

- 88 Round Track
- 9C-3 Splice Collar
- 3-BC Face Mount Bracket
- 203-L Apron Hanger Plastic Wheels
- 203-L Apron Hanger Steel Wheels w/Bearings
- 303-T Roll Trolley Plastic Wheels
- 303-T Roll Trolley Steel Wheels w/Bearings
- 540 Door Stop
- 540 Door Stop
- 537 Door Stop
- 537 Door Stop
- 50-5 Door Pull
- 50-5 Door Pull
- 630 Sliding Latch
- 630 Sliding Latch
- 630 Sliding Bolt Latch
- 630 Sliding Bolt Latch
- 9-2C Double Track Bracket

## ABOUT WESTERN PRODUCTS:

The quality of the products we produce reflects a pride in workmanship for more than seventy five years at the same location. The current owner has increased the emphasis on growth in **new products, competitive pricing** and **customer service**.

At Western, computer-aided manufacturing enters the rural building hardware market daily. For example: our round track line will provide consistently sure, smooth door movement with fingertip guidance. Steel ball bearing trolleys roll effortlessly in track which may be top or face mounted on the door frame, at your customer's convenience.

Watch for more new product announcements from Western, and expect our reputation for quality and service to endure in the years ahead.

**Western's** warranty is for any manufacturing defects, or malfunctions of their products. **Western** will replace any and all products that fail under the manufacturers specified work loads, and or applications.

### Terms and Conditions:

**Terms:** 2/10 net 30 days on approved credit. A service charge of 1.5% per month will be charged on all past due accounts, when ordering broken cartons, a \$5.00 charge will apply per order.

**Returns:** Stock Items - All returns are to be approved and allowed at the discretion of Western Products. There will be a 15% restocking charge plus freight if the return is allowed. Special Items are not returnable.

**Workmanship Guaranteed:** Stock and custom items must have return authorization from Western Products. If defective, credit will be issued for the product and freight within fifteen (15) days of the return. It is the customer's responsibility to examine incoming product for damage/shortage prior to signing accepting papers. Freight claims must be filed with the carrier whenever applicable.

**Special Orders:** All special orders must be confirmed in writing before the order will be processed.

**Order Cancellation:** Stock Items - Any time before shipment. Special Items - Any time before production has begun.





P.O. Box 545 • New Castle, IN 47362

(800) 553.5142

Indiana (765) 529.6230

FAX (765) 529.2880

[www.westernproductsinc.com](http://www.westernproductsinc.com)

E-mail : [terry\\_westernprod@sbcglobal.net](mailto:terry_westernprod@sbcglobal.net)

[shell\\_westernprod@sbcglobal.net](mailto:shell_westernprod@sbcglobal.net)

